

REA JET

INDUSTRIAL CODING AND
MARKING SOLUTIONS -
MADE IN GERMANY

REA JET GK 2.0

High Resolution Inkjet Printers (Piezo)



REA JET GK 2.0

Versatile and Multiple Line



The new generation of high resolution Piezo inkjet printers is ideal for coding and marking on absorbent surfaces, such as paper, cardboard, wood, textiles etc. with a variable print height of up to 100 mm per print head.

With the new generation of print heads, alphanumeric texts, 1D/2D codes and graphics such as company logos or product images can be freely combined. Direct printing on packaging and product surfaces with a horizontal resolution of up to 1200 dpi is a cost effective and flexible alternative to labels or pre-printed cardboards.

The combination of industrial environmental proven Piezo technology together with the robust system construction design ensures extremely high printing system reliability at product speeds of up to 200 m/min, even under most difficult production conditions. The optimized print quality with increased edge sharpness leads to substantially improved code quality.

Depending on the installation situation, different device configurations are available. The compact design enables simple integration.

For devices equipped with the optional maintenance module, the print head can be quickly and easily cleaned. Thereby the maintenance effort is reduced to a minimum and ensures the best possible availability of the marking system within production logistics.

The REA GK 2.0 is operated via the REA JET TITAN platform the most modern single operating concept for all REA JET coding and marking technologies. In addition to cost and time savings, the risk of human error has been reduced significantly. We provide the widest range of operation possibilities available today.

Labels and print layouts are quickly and easily created in the REA JET Label Creator, which can be designed and printed in the shortest time



Print head GK 768 and ink supply unit with umbilical connection (100 cm) for flexible print head alignment

Marking of cardboard boxes

Flexible use

- Different device versions depending on requirements
- New high-performance print head generation
- Higher-contrast print results for improved first-pass reading rates of barcodes
- Simple operation and maintenance
- Availability of many user languages
- XML based data and communication structure
- Connection of international USB keyboards and scanners



Print head GK 768 with integrated ink supply unit for marking on side

Print functions

- Free selectable horizontal print resolution up to 1200 dpi
- High print quality with very good edge sharpness
- Alphanumeric texts, barcodes, Data Matrix codes and logos
- Printing of variable data, e.g. date, counter, time, shift code, database contents

Print heads

- GK 768/256: print height up to 100 mm
- GK 384/128: print height up to 50 mm
- Protection class IP64

Ink supply unit

- Ink supply unit for use with 500 ml ink bottles
- Special solvent-free inks
- Ink bottles can be replaced without stopping the printing process
- Optional maintenance module

Environmental conditions

- Operating temperature: +10 °C to +40 °C (+40 °F to +104 °F)
- Max. air humidity: 90 %, non-condensing

Print distance

- For text: up to 12 mm
- For 1D/2D codes: up to 6 mm

Weights

- Print head GK 768: 3970 g (ink supply unit included)
- Print head GK 384: 3170 g (ink supply unit included)



Print head GK 384 and ink supply unit

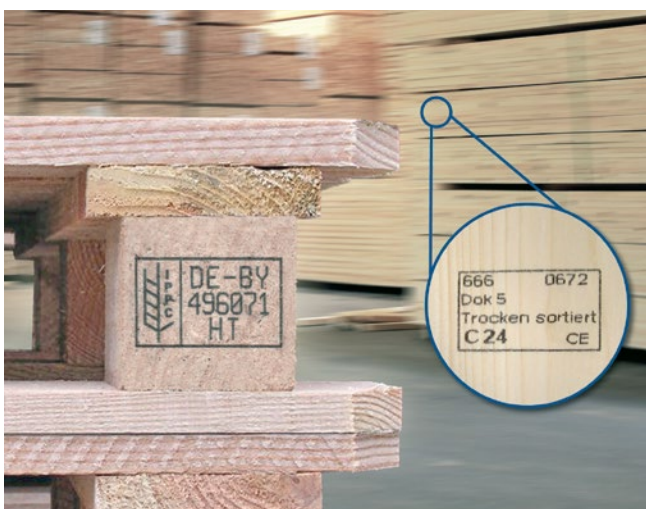

IPPC and CE logo marking on wood

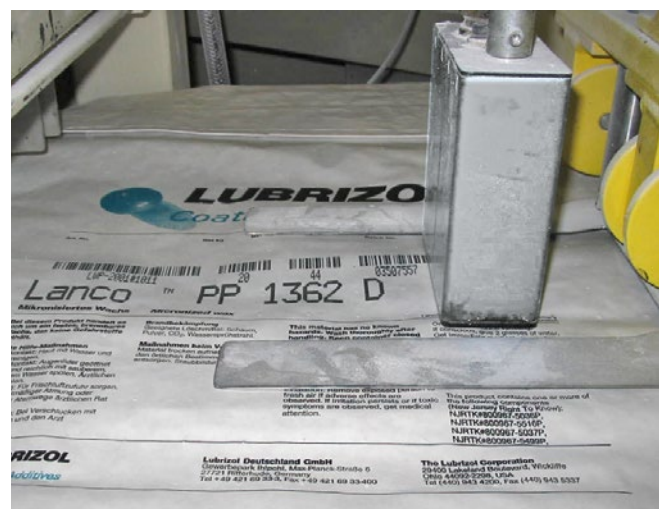

Marking of paper bags

REA JET GK 2.0 Controller

Designed for Global Compatibility

- Sturdy and high-quality stainless-steel housing designed for daily work in harsh and rugged industrial environments
- Full Unicode support: all global languages can be printed for companies with international customers
- Support of all True Type Fonts (TTFs): maximum design flexibility for your print texts
- 24 V power supply: for direct integration into machines and plants
- Wide range power supply available: for immediate global use
- XML based data structure and communication protocol: globally standard for data compatibility
- Integrated VNC-Server: Remote maintenance tool for diagnosis and support
- Protection Class IP65: dust-proof and splash water protected for toughest industrial conditions
- Uniform, cross-device communication protocol for condition monitoring across multiple devices: allowing user-specific signal processing
- Consistent graphical user interface WYSIWYG: realistic display of print contents
- Integrated web server: enables print system operation via PC, tablets or smartphone
- Max. 2 print heads connectable



REA JET GK 2.0 Controller

Connectivity

- Ethernet 1 Gbit
- 3 x USB
- 6 digital inputs
- 4 digital outputs

Power supply

- 24V DC from SELV-Power Supply
- External power supply IP67 (100 V - 277 V AC, 50 - 60 Hz)

Weight

- Controller: 3900 g

The REA JET TITAN Platform:

The most modern operating concept for all REA JET Ink and Laser Marking Systems



Operation with gloves

Central push-turn jog-dial knob for operation with gloves directly at the production line



Touch operation

Touch-sensitive screen for operation directly at the production line



WLAN browser operation

Browser operation using mobile devices (tablet, smartphone) via WLAN / WebGUI



PC operation

Remote control using a PC workstation or production control station via network



Remote maintenance

Remote maintenance and operation possible via VNC server



Keyboard input

For recurrent, large text entries at the production line, use of international USB keyboards possible

Dimensions (in mm)

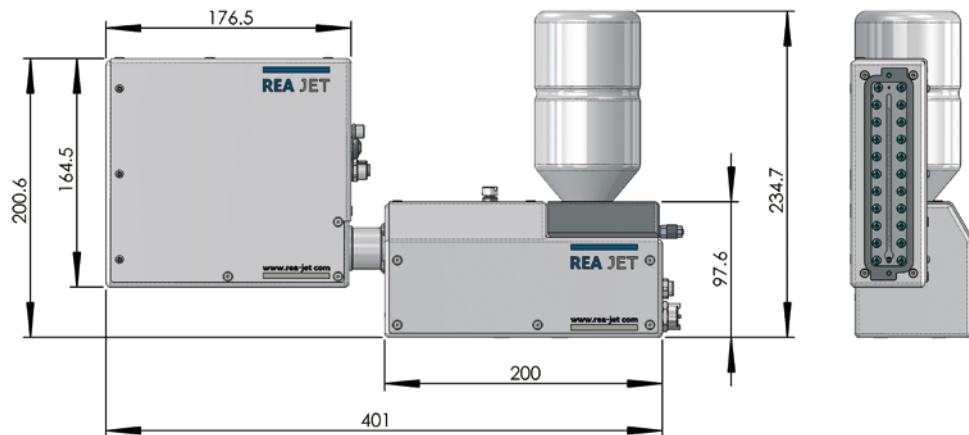

REA JET GK 2.0 with
print head GK 768/256

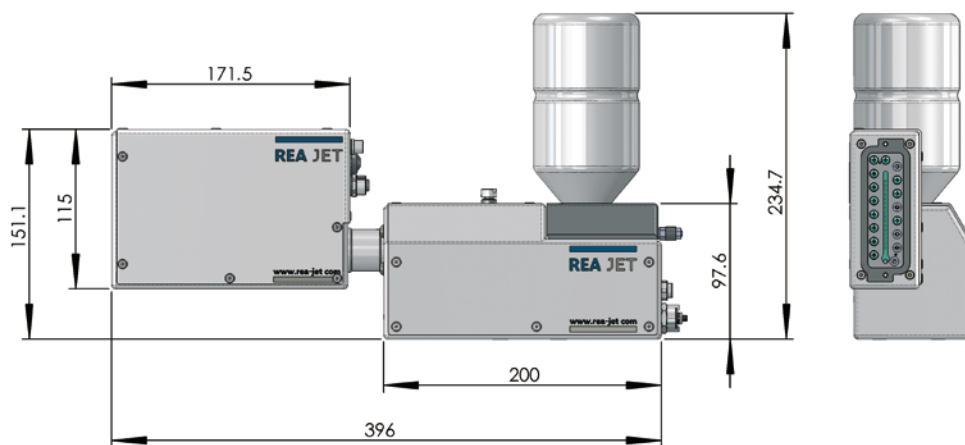
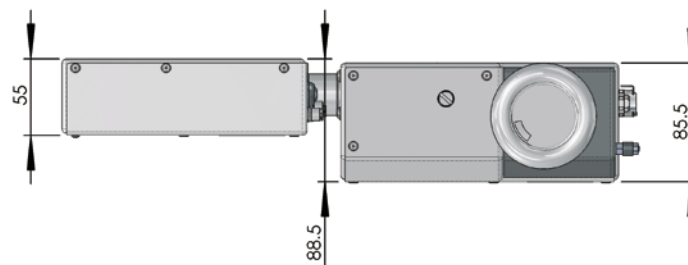

REA JET GK 2.0 with
print head GK 384/128

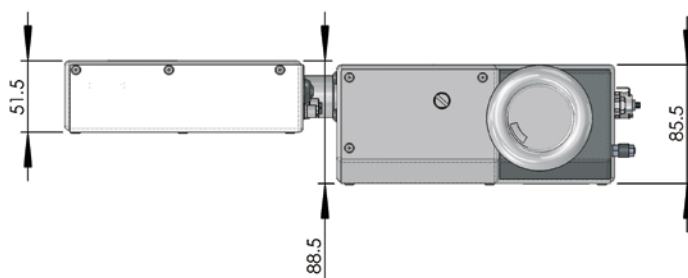

REA JET



REA Elektronik GmbH

Teichwiesenstrasse 1

64367 Muehltal

Germany

T: +49 (0)6154 638-0

F: +49 (0)6154 638-195

E: info@rea-jet.de

www.rea-jet.com